

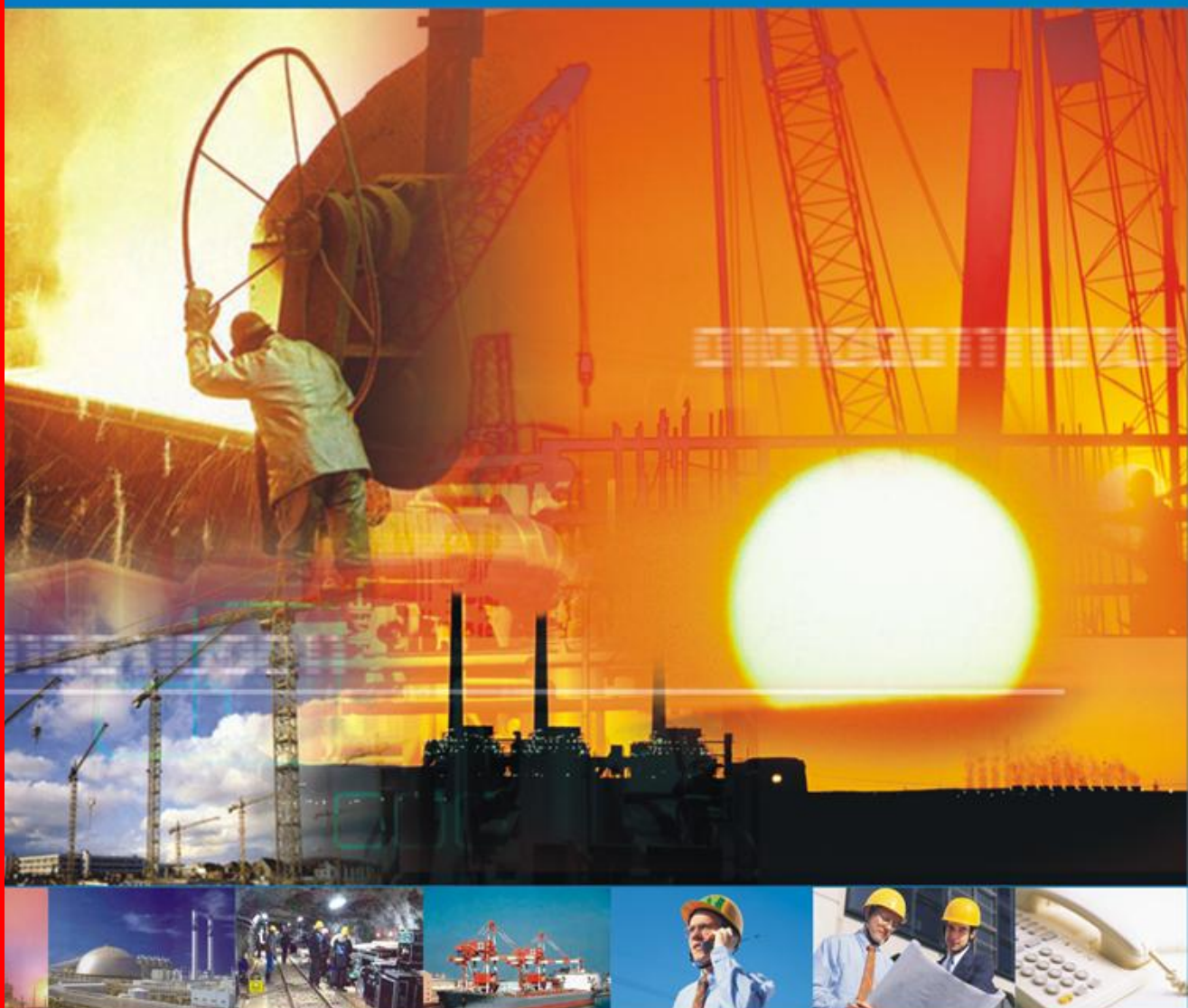

inter**King**

Explosion-proof Control Device

INTERKING ENTERPRISES LTD.



INDEX



1. Explosion-proof Control Device

(1) Static Grounding Indicator K1SCG1/K1SCG2.....	1
(2) Static Grounding Indicator K1SCG3.....	3
(3) Fire Alarm Controller K1FM01	5
(4) Ethernet Converter K1EC01	7
(5) Power Supply K1PS01	9
(6)Option KSGC/KSGC-1 · K1WB36 · KCR10 · OS-A2F-UFN-20	11
2. Product List.....	12



mail

InterKing

Explosion-proof Control Device – Static Grounding Indicator

MODEL

K1SCG2

Characteristics



- Aluminum alloy enclosure, powder coated, corrosion-resistant, impact-resistant
- Suitable for Zone 1 hazardous area
- Power Indicator Light : Red LED
- Grounding Indicator Light : Green LED light turns on when the connection to ground is maintained
- Impedance: Standard resistance should be under 20Ω to trigger the device ($5\Omega\sim 250\Omega$ is adjustable)
- ON-DELAY: 0.5s~30s (Delay of output contact)
- K1SCG1 : Power red light(R), grounding green light(G), and push button
- K1SCG2 : Power red light(R), grounding green light(G), push button, and buzzer
- Patent number : M603658 / M599469
- Option:
 - SUS304 Stainless Steel Grounding Clip (Model : KSGC / KSGC-1)
※ Patent number : M595350
 - Explosion-proof Sound and Light Alarm (Model : K1WB36)
 - Power Cord Reel (Model : KCR10)
 - Explosion-proof cable gland (Model: OS-A2F-UFN-20)

MODEL

K1SCG2

Specifications

Model		K1SCG1 / K1SCG2
Power	Voltage	110~220 Vac
Material	Structure	Aluminum alloy
Output Contact	Withstands a maximum current of 8A/250 VAC load (x4 sets)	
Environment	Certification	CNS: Ex d IIB+H ₂ T6 Gb / Ex tb IIIC T85°C Db
	IP Degree	IP66
	Ambient temperature	-20°C~+40°C
Patent number	M603658 / M599469	
Packing	Dimensions	410(L) x 335(W) x 310(H) mm
	Weight	12.8 kg

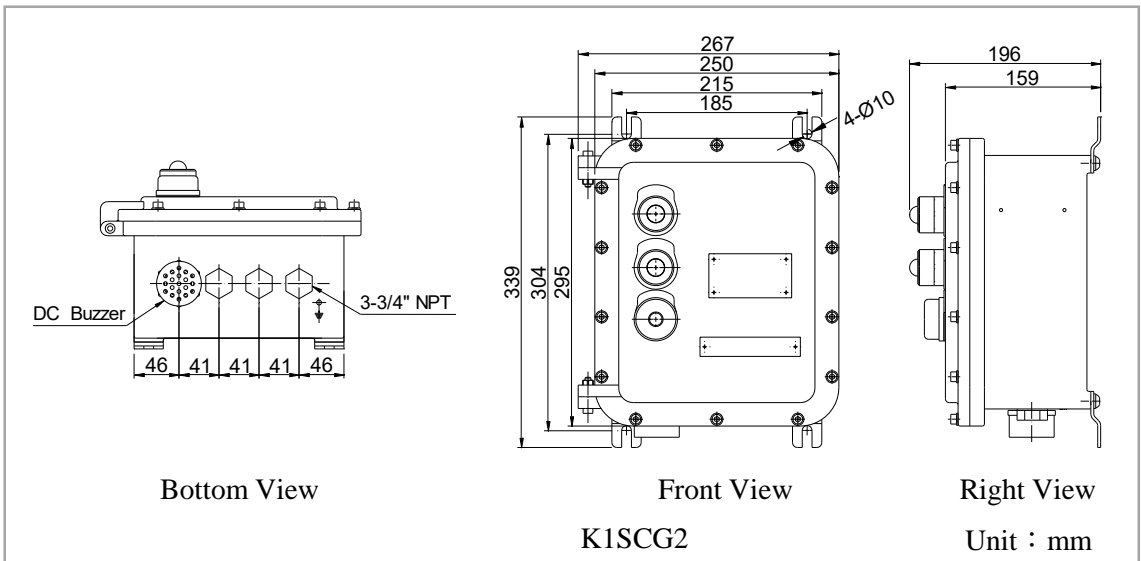

Explosion-proof Control Device – Static Grounding Indicator

MODEL

K1SCG3

Characteristics



K1SCG3

- Aluminum alloy enclosure, powder coated, corrosion-resistant, impact-resistant
- Suitable for Zone 1 hazardous area
- Power Indicator Light : Red LED
- Grounding Indicator Light : Green LED light turns on when the connection to ground is maintained
- Selection switch: Auto-Off- ByPass the grounding function.
- Impedance: Standard resistance should be under 20Ω to trigger the device ($5\Omega\sim 250\Omega$ is adjustable)
- ON-DELAY: 0.5s~30s (Delay of output contact)
- Cable entries: 3/4" NPT x 3
- K1SCG3: Power red light (R), grounding green light(G), selector switch, and buzzer
- Option:

SUS304 Stainless Steel Grounding Clip (Model : KSGC / KSGC-1)

※ Patent number : M595350

Explosion-proof Sound and Light Alarm (Model : K1WB36)

Power Cord Reel (Model : KCR10)

Explosion-proof cable gland (Model : OS-A2F-UFN-20)

MODEL

K1SCG3

Specifications

Model		K1SCG3
Power	Voltage	110~220 Vac
Material	Structure	Aluminum alloy
Output Contact	Withstands a maximum current of 8A/250 VAC load (x4 sets)	
Environment	Certification	CNS: Ex d IIB+H ₂ T6 Gb / Ex tb IIIC T85°C Db
	IP Degree	IP66
	Ambient temperature	-20°C~+40°C
Packing	Dimensions	410(L) x 335(W) x 310(H) mm
	Weight	12.8 kg

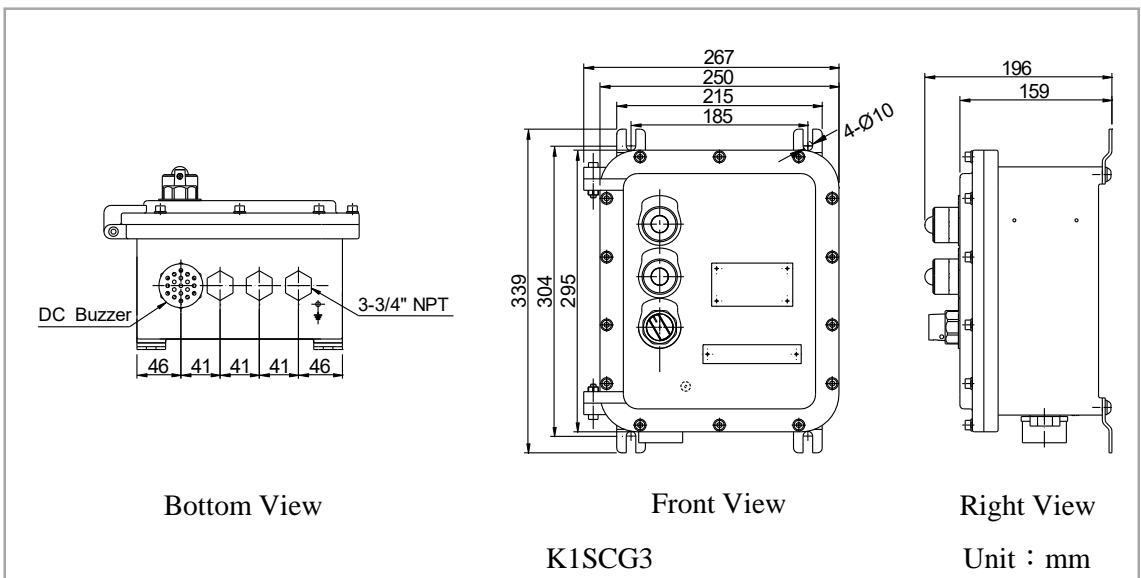

Explosion-proof Control Device – Fire Alarm Controller

MODEL

K1FM01

Characteristics



K1FM01/K1FM02/K1FM03/K1FM04

- Aluminum alloy enclosure, powder coated, corrosion-resistant, impact-resistant
- Suitable for Zone 1 hazardous area
- K1FM01: SIGA-CT1 single input module x 1
- K1FM02: SIGA-CT1 single input module x 3
- K1FM03: SIGA-CT2 dual input module x 3
- K1FM04: SIGA-CT2 dual input module x 1 and SIGA-CR control relay module x 2
- Cable entries: 3/4" NPT x 4
- CNS certified, Ex d IIB+H₂ T6 Gb / Ex tb IIIC T85°C Db

MODEL

K1FM01

Specifications

Model		K1FM01 / K1FM02 / K1FM03 / K1FM04
Power	Voltage	15.2~19.95 Vdc
Material	Structure	Aluminum alloy
Environment	Certification	CNS: Ex d IIB+H ₂ T6 Gb / Ex tb IIIC T85°C Db
	IP Degree	IP66
	Ambient temperature	-20°C~+40°C
Packing	Dimensions	410(L) x 335(W) x 310(H) mm
	Weight	12.8 kg

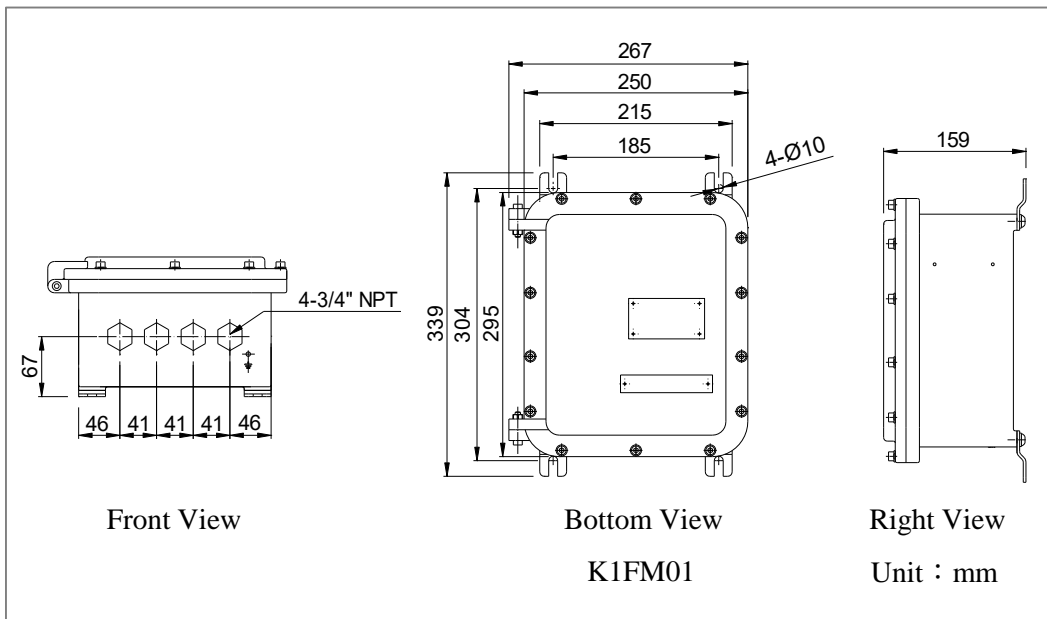

Explosion-proof Control Device – Ethernet Converter

MODEL

K1EC01

Characteristics



K1EC01 / K1EC02 / K1EC03 / K1EC04 / K1EC05 / K1EC06

- Aluminum alloy enclosure, powder coated, corrosion-resistant, impact-resistant
- Suitable for Zone 1 hazardous area
- K1EC01: 5-port Ethernet switch and power supply
- K1EC02: 8-port Ethernet switch and power supply
- K1EC03: Fiber Ethernet converter and power supply
- K1EC04: LAN extender and power supply
- K1EC05: Serial device converter and power supply
- K1EC06: Ethernet extender x2 and power supply
- Cable entries: 3/4" NPT x 4
- CNS certified, Ex d IIB+H₂ T6 Gb / Ex tb IIIC T85°C Db

MODEL

K1EC01

Specifications

Model		K1EC01 / K1EC02 / K1EC03 / K1EC04 / K1EC05 / K1EC06
Power	Voltage	110~220 Vac
Material	Structure	Aluminum alloy
Environment	Certification	CNS: Ex d IIB+H ₂ T6 Gb / Ex tb IIIC T85°C Db
	IP Degree	IP66
	Ambient temperature	-20°C~+40°C
Packing	Dimensions	410(L) x 335(W) x 310(H) mm
	Weight	12.8 kg

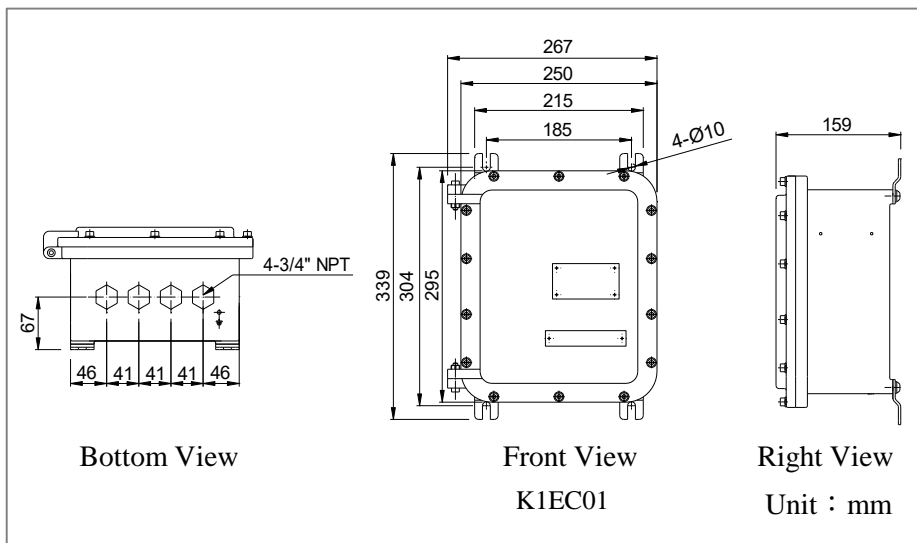

Explosion-proof Control Device – Power Supply

MODEL

K1PS01

Characteristics



K1PS01

- Aluminum alloy enclosure, powder coated, corrosion-resistant, impact-resistant
- Suitable for Zone 1 hazardous area
- Power Supply alternatives :

Type	Power	Voltage	Current
A	40W	24 VDC	1.7A
B	60W	24 VDC	2.5A
C	96W	24 VDC	4A

- Cable entries: 3/4" NPT x 4
- CNS certified, Ex d IIB+H₂ T6 Gb / Ex tb IIIC T85°C Db

MODEL

K1PS01

Specifications

Model		K1PS01
Power	Voltage	110~220 Vac
Material	Structure	Aluminum alloy
Environment	Certification	CNS: Ex d IIB+H ₂ T6 Gb / Ex tb IIIC T85°C Db
	IP Degree	IP66
	Ambient temperature	-20°C~+40°C
Packing	Dimensions	410(L) x 335(W) x 310(H) mm
	Weight	12.8 kg

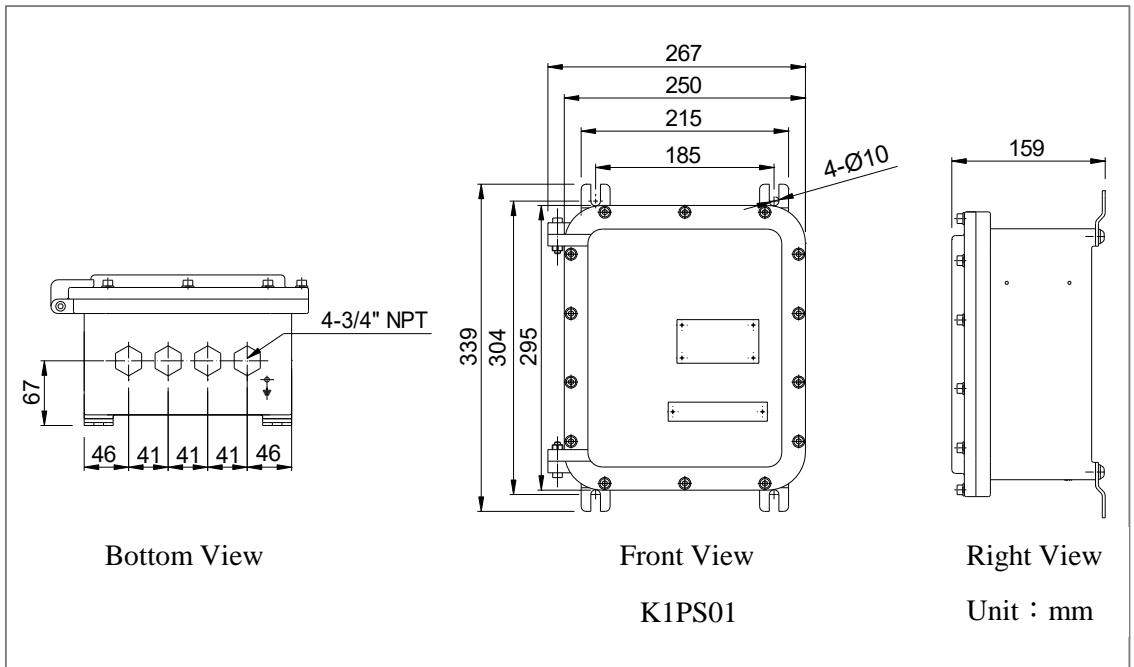





MODEL

KSGC / KSGC-1 · K1WB36 ·
KCR10 · OS-A2F-UFN-20

Option

Characteristics

			
KSGC KSGC-1	K1WB36	KCR10	OS-A2F-UFN-20

KSGC / KSGC-1 SUS304 Stainless Steel Grounding Clip

- Integrally formed, SUS304 stainless steel material, powder coated, corrosion-resistant, impact-resistant
- Especially design for equipment grounding use
- KSGC: Standard type KSGC-1: Cable protection type
- Patent number: M595350

K1WB36 Explosion-proof Compact Strobe

- Integrally formed, SUS316 stainless steel material, corrosion-resistant, impact-resistant
- High frequency buzzer / High brightness LED flashing light
- LED light: Red

KCR10 Power Cord Reel

- Wire Specifications: 2.5mm²*2C
- Cable length: 10M
- Packing dimension: 340mm x 170mm x 300mm
- 15M/20M/30M lengths are also available for selection



OS-A2F-UFN-20 Explosion-proof Cable Gland (3/4"NPT)

- Explosion-proof enclosure
- TS certified, Ex d IIC Gb/ Ex eb IIC Gb / Ex tb IIIC Db

Product List

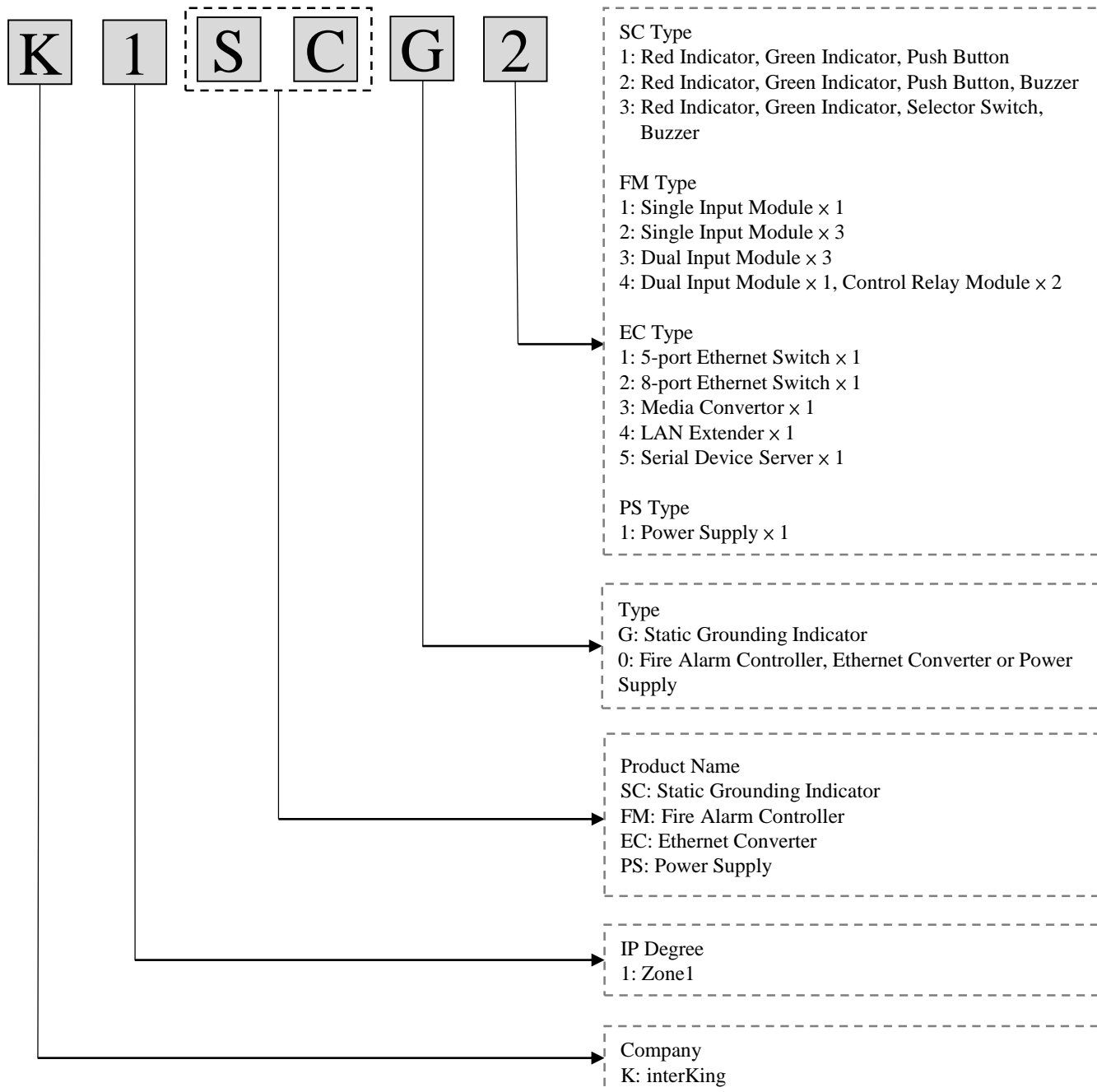



INTERKING ENTERPRISES LTD.

Production base

No.50, Minquan St., Daliao Dist., Kaohsiung City 831115, Taiwan

TEL:+886-7-7337500

FAX:+886-7-7337506

E-mail: sales@interking.com.tw

Website : <http://www.interking.com.tw>

interKing and Interking logo are registered trademarks of Interking Enterprises Ltd.

All rights reserved.

Printed 1/2026 V1.0

INTERKING ENTERPRISES LTD.